



OPERATING INSTRUCTIONS AND PARTS LIST FOR

All 21" hose reels

HOSE REELS

IMPORTANT

**READ THIS MANUAL CAREFULLY
BEFORE INSTALLING, OPERATING, OR
SERVICING THIS EQUIPMENT**

PERSONNEL SAFETY

Personal injury and/or equipment damage may result if proper safety precautions are not observed.

- Ensure that reel is properly installed before connecting input and output hoses.
- Bleed fluid/gas pressure from system before servicing reel.
- Before connecting reel to supply line, ensure that pressure does not exceed maximum working pressure rating of reel.
- Remember, even low pressure is very dangerous and can cause personal injury or death.
- Be aware of machinery and personnel in work area.
- If a leak occurs in the hose or reel, remove system pressure immediately.
- A high tension spring assembly is contained within the reel. Exercise extreme caution.
- Pull hose from reel by grasping the hose itself, not the control valve.
- Ensure that reel, hose, and equipment being serviced are properly grounded. Use an ohmmeter to check ground continuity.
- If reel ceases to unwind or rewind, remove system pressure immediately. Do not pull or jerk on hose!
- Treat and respect the hose reel as any other piece of machinery, observing all common safety practices.

DIMENSIONAL DATA

	A	20 1/4"
	B	19"
	C	7 7/8"
	D	3 7/8"
	E	6 3/4"

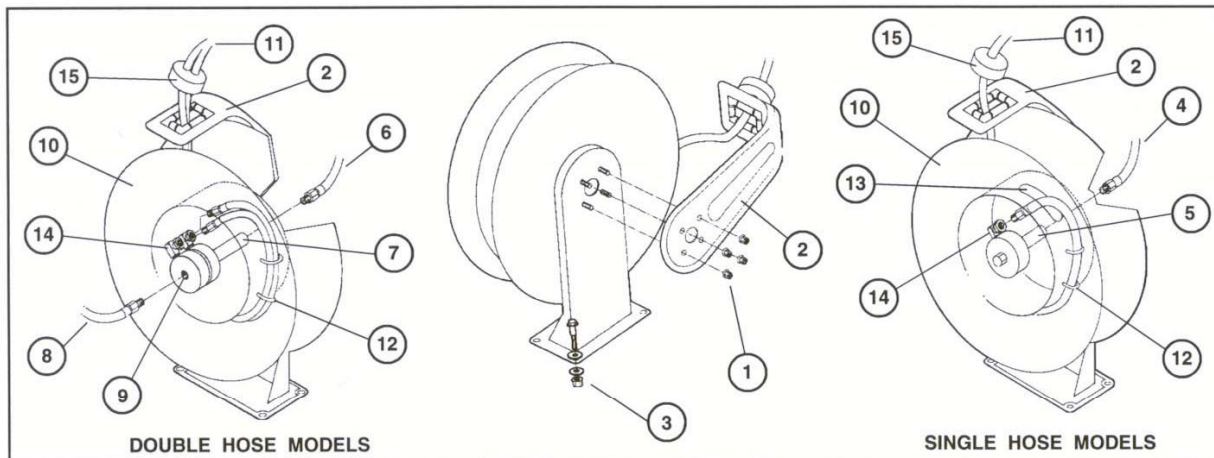

DOUBLE HOSE MODELS

SINGLE HOSE MODELS

INSTALLATION INSTRUCTIONS

NOTE: Install cabinet reels in accordance with cabinet installation instructions.

MOUNTING

CAUTION: Unless reel was specified differently when ordering, maximum installation height is 16 feet. Do not exceed this distance.

1. Unpack and inspect reel for damage. Turn by hand to check for smooth operation. Check for completeness.
2. Configure reel for top, side or bottom-wind hose dispensing by removing nuts (1) securing guide arm bracket (2). Position guide arm bracket to desired location, and replace nuts.
Caution: When changing guide arm positions, the U-bolt must be placed in the proper location as instructed in figure A on page 4. The reel can "latch out" during use if this instruction is not adhered to.
3. Position reel on floor, wall, or ceiling. Secure into place using four (customer supplied) bolts (3).

INSTALLING THE INPUT HOSE/S

WARNING: Ensure that supply line pressure does not exceed maximum working pressure rating of reel. Apply pipe thread sealant to all threads on Standard/ Stainless/Twin Hydraulic reels only.

CAUTION: Use flexible hose connection at input. Do not use rigid plumbing.

1. For Standard, Stainless, Enclosed or Stainless Shaft and Swivel reels, connect supply line hose (4) to main shaft input (5) as indicated in illustration.

For Twin Hydraulic reels, connect supply line hose (6) to main shaft input (7) and return line (8) to swivel output (9) as indicated in illustration.

For Twin Weld reels, connect input oxygen hose (6) to main shaft input (7) and input acetylene hose (8) to swivel input (9) as indicated in the illustration.

INSTALLING THE OUTPUT HOSE/S

WARNING: Use extreme caution; reel under tension. Avoid releasing latch mechanism. Apply pipe thread sealant to all threads on Stainless/ reels only. Pipe thread sealant is not recommended on standard/enclosed/twin hydraulic.

1. Manually turn sheave (10) until spring is tight, back off 3 turns, then latch.
2. Route output hose/s (11) through guide arm bracket (2), U-bolts (12), then through cutout (13) in spool as indicated in illustration.
3. Connect output hose/s (11) to swivel (14) as indicated in illustration.
4. Tighten U-bolts (12).
5. Charge hose/s. Momentarily open control valve to purge hose/s of gases. When fluid appears at control valve, close valve. With hose/s fully charged, release latch and wind output hose/s onto reel.
6. Install hose bumper (15).

ADJUSTMENTS

WARNING: Use extreme caution; reel under tension. Avoid releasing latch mechanism. If necessary, adjust spring tension on reel by adding or removing wraps of hose from spool, one wrap at a time, until desired tension is obtained. Add wraps to increase tension. Remove wraps to decrease tension.

SERVICE INSTRUCTIONS

User servicing of the reel is limited to replacing input/output hoses only. Refer all other repairs to an authorized service person or directly to Reelcraft. Failure to do so can result in personal injury and/or equipment damage and may void the warranty.

WARNING: Rewind hose on reel, then bleed pressure from system before performing the following procedures.

1. Replace hoses in accordance with procedures given in "Installation Instructions" section of this manual.

CAUTION: When replacing drive spring, hold the center of the spring down as the hub is pulled out. If the center is allowed to raise up, the spring may escape from it's container with enough force to cause injuries.

When disposing of old or broken spring assemblies, the coils should be welded or wired together to prevent possible injury to scrap handling personnel.

2. All mating moving parts are to be lubricated with Perma Bond or Loctite anti-seize compound.
-

Call us to cross reference LUBEQ part number

PARTS COMMON TO ALL PAINTED/STAINLESS REELS

ITEM NO.	PAINTED PART NO.	STAINLESS	NO REQ.	DESCRIPTION	ITEM NO.	PAINTED PART NO.	PAINTED STAINLESS	NO REQ.	DESCRIPTION	ITEM NO.	PAINTED PART NO.	PAINTED STAINLESS	NO REQ.	DESCRIPTION
4	260011	600063	1	Sheave Assembly	13	NONE	S47-66	1	3/8-16 x 1/2" Setscrew	22	S600018	S600069	1	Latch Pawl Ass'y
6	S600621	S600621	1	Spring Arbor Ass'y	14	S600017	S600068	1	Guide ARm w/rollers	23	S76-106	S74-106	1	3/8-24 Jam Nut
7	S260069	S260069	1	Gasket	16	300017	S73-5	4	5/16-18 Locknut	24	S260031	260256	1	Springcase stud
8	S260074	600065	1	Spring Case Ass'y	17	S82-15	S95-22	1	10-32 X 3/8" Nyloc Nut	26	300070	S96-13	4	1/4-20 x 3/8" Locknut
9	300011	260239	6	10-32 Hex Locknut	18	S280-18	S72-8	1	1/2-20 x 5/8" Hex Nut	27	300039	S108-4	4	1/4" Flat washer
11	300007	S147-26	2	1 1/4" Snap Ring	19	S260067	S260067	1	Latch Spring					
12	600016	600067	1	Base Assembly	20	S400012	S260225	1	Bushing					
13	S35-51	NONE	1	1/2-13 Setscrew	21	S20-110	S46-110	1	10-32 x 7/8" Screw					

PARTS COMMON TO STANDARD REELS (NON STAINLESS, TW OR TH)

ITEM NO.		NO. REQ.							
1	Swivel Assembly	1	S600007	S600888	S602033	S600007	S600888-1	S602033	S602026
5	Drive Spring Ass'y	1	S260053	*Note	S260053	S260053	S260037	S260053	S600023
8	Spring Case Ass'y	1	600065	600065	600065	600065	600065	600065	600065
10	Main Shaft	1	S260095	S260095	S260095	S260095	S260095	S260095	260095-1
15	Hose Bumper Ass'y	1	1-HR1004-3	1-HR1004-3	1-HR1004-3	1-HR1004-3	1-HR1004-3	2-HR1004-3	3-HR1004-3
22	Latch Pawl Ass'y	1	S600018	S600018	S600018	S600018	S600018	S600018	S600018
25	U-bolt	2	2-117440	2-117440	2-117440	3-117440	2-117440	3-117440	5-117440
28	Swivel Union	1	S257-11	S257-26	S257-26	S257-11	S257-26	S257-26	None

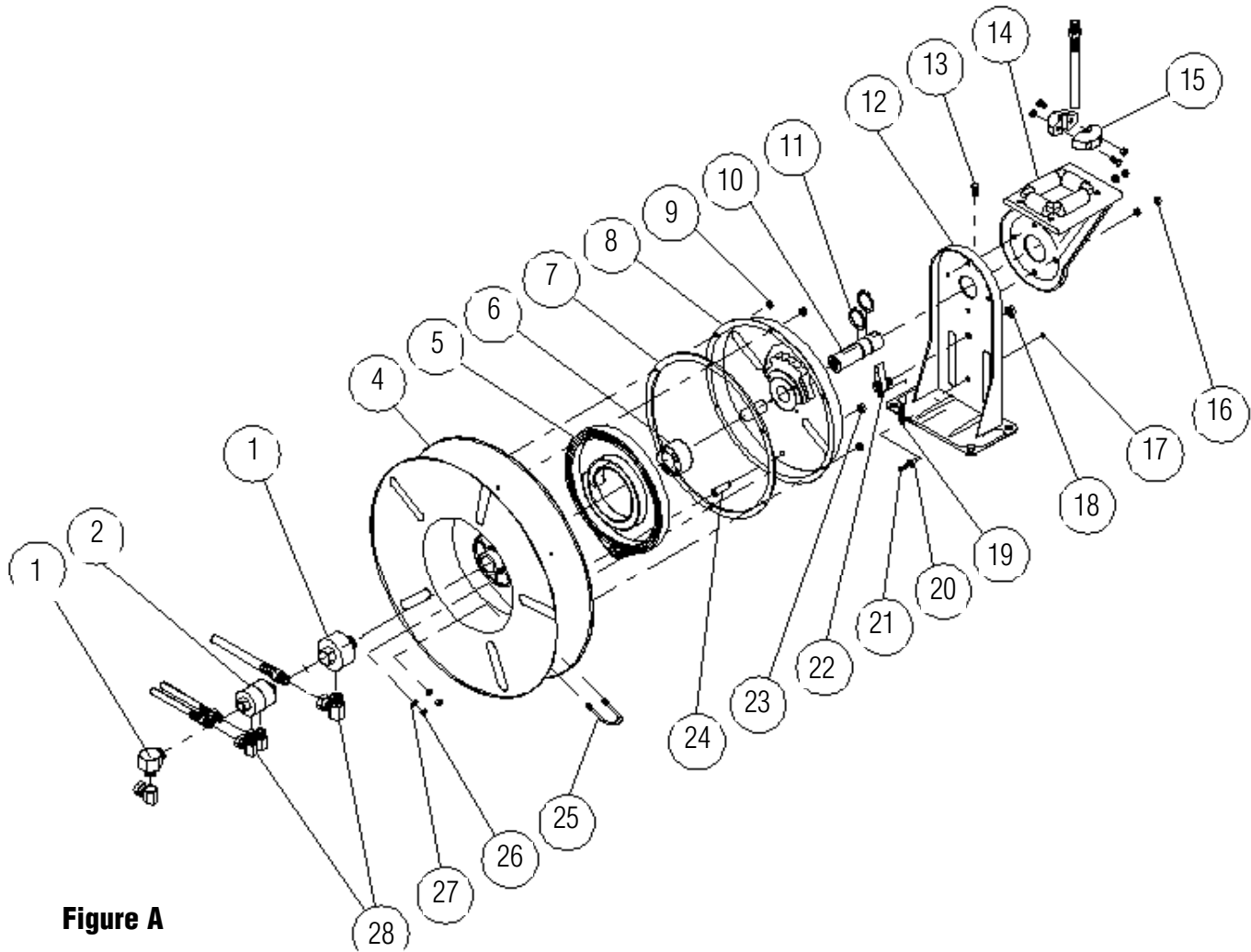

Figure A

<p>TW HOSE CLAMP LINEA DE ARRIBA ABRAZADERA DE LA MANGURA ENROULE DE HAUT CRAMPON DE TUYAU</p>	<p>SW HOSE CLAMP LINEA DEL LADO ABRAZADERA DE LA MANGURA ENROULE DE COTE CRAMPON DE TUYAU</p>	<p>BW HOSE CLAMP LINEA DE ABAJO ABRAZADERA DE LA MANGURA ENROULE DE BAS CRAMPON DE TUYAU</p>