

FM-530 Series

MECHANICAL

FUEL METER

Owner's Manual



TABLE OF CONTENTS

General Information.....	2
Installation.....	2
Operation.....	3
Calibration.....	4
Maintenance.....	4
Troubleshooting.....	5
Specifications.....	5
Illustrated Parts Drawing.....	6
Illustrated Parts List.....	7
Parts and Service.....	7

GENERAL INFORMATION

Congratulations on receiving your new meter. This manual should assist you in operating and maintaining your mechanical fuel meter. Please take a few moments to read these instructions before installing and operating your fuel meter. If you need assistance, contact the dealer from whom you purchased your meter.

Safety Instructions

Please read, understand, and follow the safety instructions given here. It is your responsibility to ensure that all equipment operators have access to adequate instructions concerning safe operation and maintenance.

1. This meter is designed for use only with thin viscosity petroleum fuels such as gasoline (up to 15% alcohol blends such as E15), diesel fuel (up to 20% biodiesel blends such as B20), biodiesel (B100) and kerosene.
2. Do not use this equipment for dispensing any fluids other than those for which it was designed. To do so may damage the meter and will void the warranty.

3. Observe precautions against fire or explosion when dispensing fuel. Do not operate the meter in the presence of any source of ignition including running or hot engines, lighted cigarettes, or gas or electric heaters.
4. Any components such as hose, nozzle, or pump added to your meter must be statically grounded and approved for use with petroleum fuels.
5. Avoid prolonged skin contact with petroleum fuels. Use protective goggles, gloves, and aprons in case of accidental splashing or spillage. Change saturated clothing and wash skin contact areas promptly with soap and water.

The FM-530 Series of Mechanical Fuel Meters are designed for the field measurement of thin viscosity petroleum fuels only and are intended for use with pump systems in the 5 to 30 GPM or 19 to 114 LPM flow range (not intended for gravity flow systems). Using mechanical gears, these meters translate flow data from a nutating disc into calibrated units which are indicated on the face of the meter. This meter is factory calibrated for diesel fuel. Field calibration feature is available for other fluids, see Calibration section.

INSTALLATION

Before installing your meter, review the safety instructions given above. Examine your meter to make sure there are no visible signs of shipment damage. Plan your meter installation by reviewing the following procedures. Your system must be mounted on a vented tank. If the tank is unvented, your local dealer or distributor can supply a pressure cap.

If the meter is located in a rigid piping system where the fluid is trapped (for example, by gravity, valves or nozzles) thermal expansion of the fluid can create pressure spikes that can damage a meter. Install a thermal relief valve or otherwise allow for thermal expansion of the fluid.

Prior to installation, determine the fitting angle desired and whether horizontal or vertical orientation is required.

Rotate Fittings

To rotate inlet and/or outlet fittings, remove the two nuts and bolts that secure each fitting. Rotate the fitting to the desired orientation. Make sure the O-ring is fully seated. Tighten the nuts and bolts snugly.

Change Orientation

1. Remove the two Phillips head screws that secure the cover to the coverplate assembly.
2. Remove the eight pairs of nuts and bolts that hold the coverplate assembly to the housing. (Figure 1) Note the position of the reset button.

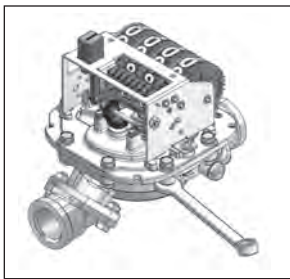

Figure 1

3. Rotate the coverplate assembly and counter to the desired orientation. Make sure the flow arrow in the housing points toward the outlet port. (Figure 2)

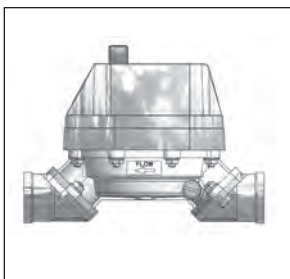

Figure 2

4. Make sure the housing O-ring is fully seated and firmly tighten the eight nuts and bolts that secure the coverplate assembly.
5. Place the reset button in position. Secure the cover to the coverplate assembly with the two Phillips head screws.

Meter Installation

1. Remove protective plugs from the meter inlet and outlet ports.
2. Wrap threaded male connections with thread tape or use a pipe sealant compound compatible with petroleum fuels. We recommend Lock-Tite thread sealant at the inlet fitting in horizontal orientation.
3. Install the meter on the pump using an appropriately sized nipple. The meter's flow path is marked on the housing exterior with an arrow pointing toward the outlet port.
4. Install other system components on the meter and tighten snugly.

OPERATION

Before use, review the safety instructions given above. Visually check the meter to ensure it is securely connected to other system components and there is no leakage. Promptly wipe spilled fuel from the meter's exterior and other system components.

The large meter display represents the Batch Total for each fuel delivery. Before dispensing, reset the Batch Total to zero by pushing the reset button. (Figure 3)



Figure 3

The small display represents the Cumulative Total of all fuel deliveries and cannot be reset.

CALIBRATION

The meter is accurately calibrated at the factory for use with diesel fuel. Due to differences in viscosity and flowrates, the meter may require recalibration to measure other fuels or to adjust for inaccuracies.

1. Purge air from the meter and fuel system by dispensing fuel into a container until a full flow occurs. Close the nozzle.
2. Reset the meter counter to zero by pressing the reset button. (Figure 3)
3. Pump into a graduated calibration container to a specified quantity. For the greatest accuracy, be sure the container is placed on a level surface and a consistent flow rate is used. When topping off the calibration container, use a quick-open and quick-close method until the mark is reached.
4. Compare the meter display to the quantity in the container. If the display does not register the quantity on the container, adjust the meter by performing the following:
 - a. Gain access to the recessed calibration screw by turning the calibration screw cover and seal counterclockwise. Remove the cover and nylon washer. (Figure 4)

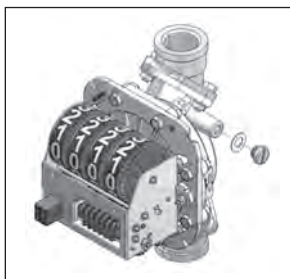

Figure 4

- b. If the meter registered **less** than the quantity in the container, turn the calibration screw **clockwise**. If the meter display read **more** than the amount in the container, turn the calibration screw **counterclockwise**.

5. Empty the calibration container and repeat steps 2 to 4 until the meter registers the quantity in the container.
6. Install the nylon washer and calibration screw cover.

MAINTENANCE

The meter's strainer should be cleaned at regular intervals, especially when low flow is detected.

Clean or Replace Strainer

1. Remove the nuts and bolts at the inlet fitting. Remove the fitting, O-ring, and strainer.
2. Using a fine brush, clean the strainer. Replace the strainer as necessary.
3. Wipe clean the inlet, housing, and O-ring groove. Coat the O-ring with oil or light grease. Make sure the O-ring is fully seated. Replace the strainer.
4. Position the inlet fitting in the desired orientation and tighten the nuts and bolts until snug.

TROUBLESHOOTING

Symptom	Probable Cause	Corrective Action
A. Meter counter does not operate. (Normal fuel delivery)	<ol style="list-style-type: none"> 1. Broken counter assembly. 2. Foreign material in counter assembly or nutator assembly. 3. Broken nutator disc pin or defective nutator assembly. 4. Jammed or broken gear train. 	<p>Replace counter.</p> <p>Remove and clean counter assembly or nutator assembly.</p> <p>Install new nutator assembly.</p> <p>Push reset to free number wheels.</p>
B. Meter counter does not operate. (Little or no fuel flow)	<ol style="list-style-type: none"> 1. Clogged strainer in meter. 2. Other system components malfunctioning. 3. Foreign material in nutator assembly. 	<p>Clean or replace strainer.</p> <p>Check all system components from tank to nozzle for clogs and/or malfunctions. Repair as necessary.</p> <p>Remove and clean nutator assembly.</p>
C. Fuel leakage.	<ol style="list-style-type: none"> 1. Leakage at counter drive shaft. 2. Leakage between coverplate and housing. 3. Leakage at fittings. 4. Leakage at threads. 	<p>Replace coverplate assembly.</p> <p>Remove coverplate and inspect for damaged, missing or incorrectly seated seal. Replace as required.</p> <p>Remove fittings and inspect for damaged, missing or incorrectly seated seals. Replace as required.</p> <p>Remove meter and reseal all threaded connections with thread tape or pipe thread sealing compound approved for use with flammable liquids.</p>

SPECIFICATIONS

	Gallon Models	Litre Models
Unit of Measure	U.S. Gallon	Litre
Flow Range	5 to 30 GPM	19 to 114 LPM
Typical Accuracy	± 2%	± 2%
Type	Nutating Disc	Nutating Disc
Housing Material	Aluminum	Aluminum
Maximum Working Pressure	50 PSIG	3.4 bar
Inlet/Outlet Fitting Size	3/4", 1" or 1-1/2"	3/4", 1" or 1-1/2"
Threads	NPT	NPT or BSPP
Maximum Batch Total	999.9	9999
Maximum Cumulative Total	999,999.9	9,999,999
Approximate Ship Weight	6.0 lbs.	2.7 kg
Maximum Dimensions: Width:	8.7 inches	22 cm
Height:	5.9 inches	15 cm
Depth:	5.7 inches	14.5 cm

Note: Accuracy is factory calibrated using diesel fuel. Field Calibration is available on all models.

ILLUSTRATED PARTS DRAWING

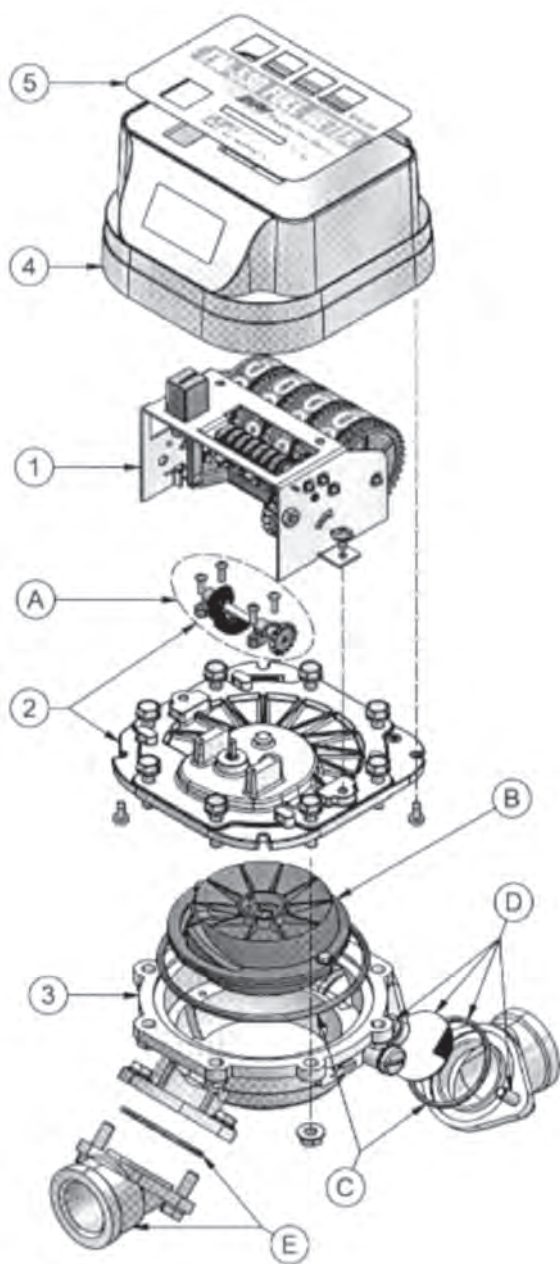

ILLUSTRATED PARTS LIST

Item No.	Part No.	Description	No. Req'd.
1	126514-05	Counter Assembly, Gallons	1
	126514-06	Counter Assembly, Litres	1
2	126514-07	Coverplate Assembly, Gallons.....	1
	126514-08	Coverplate Assembly, Litres.....	1
3	126010-1	Housing.....	1
4	126013-11	Top Cover	1
5	12620801	Decal (Gallon)	1
	12620802	Decal (Litre)	1
Items not shown:			
	111014-3	Calibration Screw	1
	111026-1	Seal, Calibration Screw	1
	111039-2	Cover, Calibration Screw.....	1
	904006-16	Washer, Calibration Screw Cover.....	1

Kits and Accessories

- A** 126514-03 Gear Assembly Kit, Gallons
- 126514-04 Gear Assembly Kit, Litres
- B** 126503-1 Nutator Assembly Kit
- C** 126509-1 Seal Kit (Housing O-Ring, Fitting O-Rings)
- D** 126512-1 Hardware Kit (Fitting O-Rings, Strainer, Screws, Nuts)
- E** 126501-1 Fitting Kit for 3/4-inch NPT (2 Fittings, 2 Fitting O-Rings)
- 126501-2 Fitting Kit for 3/4-inch BSPP (2 Fittings, 2 Fitting O-Rings)
- 126501-3 Fitting Kit for 1-inch NPT (2 Fittings, 2 Fitting O-Rings)
- 126501-4 Fitting Kit for 1-inch BSPP (2 Fittings, 2 Fitting O-Rings)
- 126501-5 Fitting Kit for 1-1/2-inch NPT (2 Fittings, 2 Fitting O-Rings)
- 126501-6 Fitting Kit for 1-1/2-inch BSPP (2 Fittings, 2 Fitting O-Rings)